

quick & easy sheet metal Projects

■ Working with sheet metal isn't difficult — if you have the right tools. All it takes to make the items shown here are some basic tools, a pair of tin snips, and the metal brake featured in ShopNotes No. 108. You'll also need the patterns on the following pages for laying out the cuts and bends.

I think you'll discover that after fabricating these few simple projects, you'll be ready to design and build your own. And to me, that's half the fun of being in the shop — applying what I've learned to build something that's practical and long-lasting.

Sheet Metal. The first thing I want to talk about is sheet metal. You'll find it in a variety of thicknesses, or gauges. The higher the gauge number, the thinner the sheet metal. For shop projects like these, 22-gauge steel is about right. It's easy to cut and bend but still has plenty of strength.

Layout. With the patterns on the following pages and your sheet metal in hand, it's time to lay out the project. Then all you need to do is cut out the pattern, make the bends, and spray on a coat of paint. The end result is a set of handy projects for your shop. 

▼ **Drawer Case & Drawers.**
Starting on page 6.



Simple Shelf. Page 2



Storage Tray. Page 3



Tool Rack. Page 4



Bit Rack. Page 5

simple Shelf

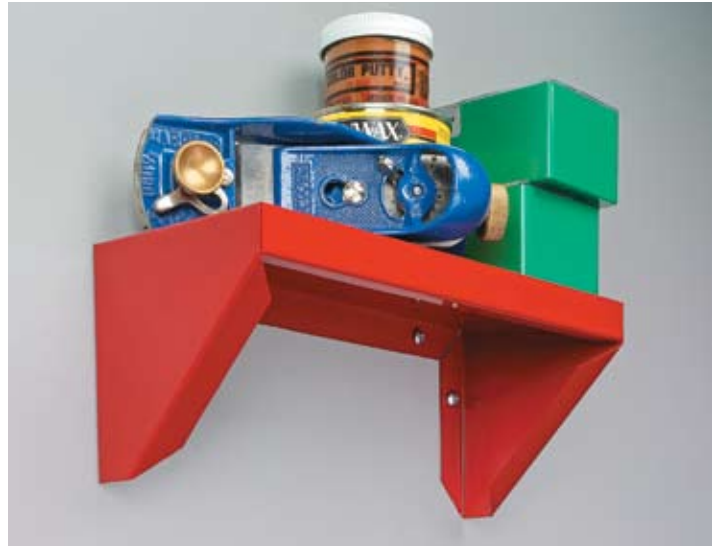

▲ **Strong and Sturdy.** By following the pattern below, you'll create a strong shelf complete with braces. A few simple bends with a sheet metal brake make it easy.

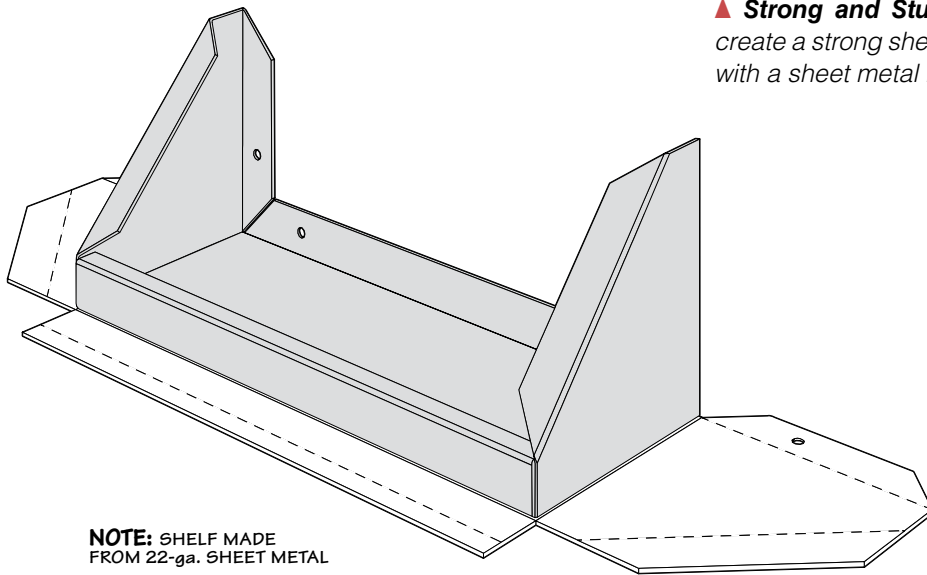

NOTE: SHELF MADE FROM 22-ga. SHEET METAL

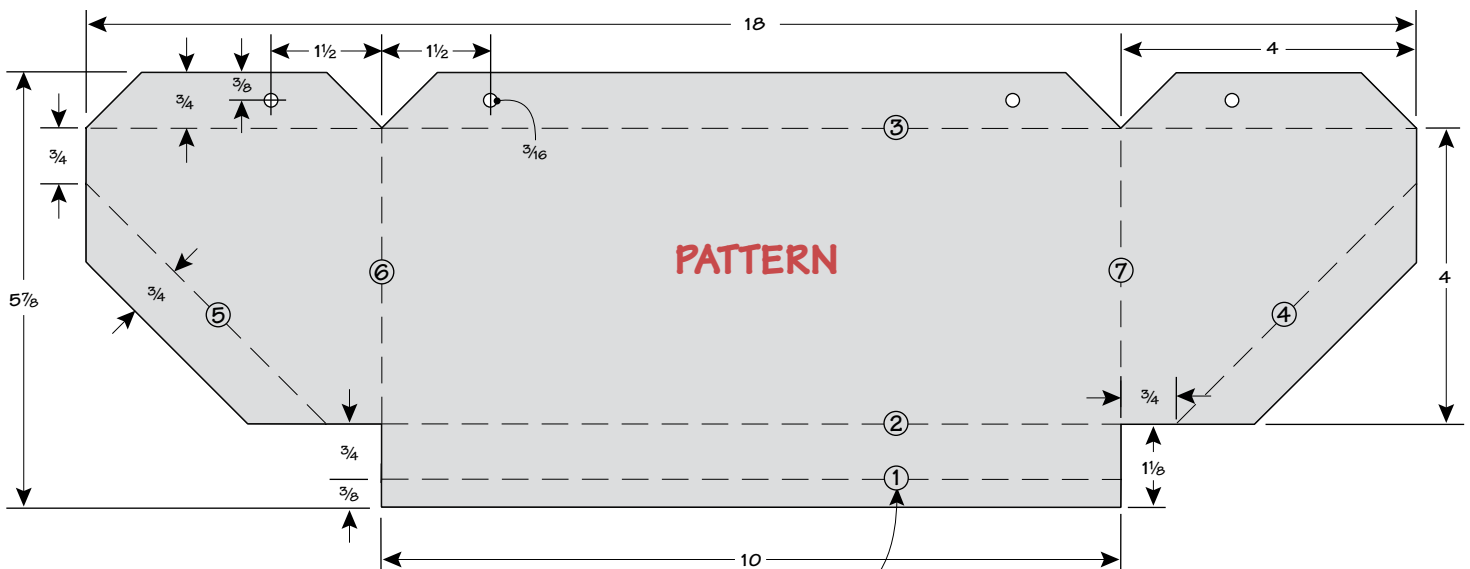
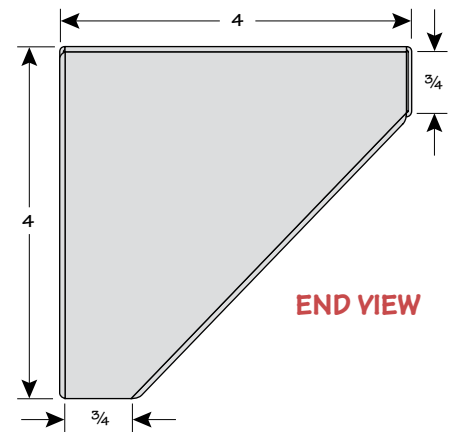

NOTE: CIRCLED NUMBERS REPRESENT SEQUENCE OF BENDS

enclosed Storage Tray



▲ **Storage Tray.** After drilling the mounting holes in the sheet metal blank, cut out the shape shown in the pattern. Then you can make the bends to form the flanges and sides.

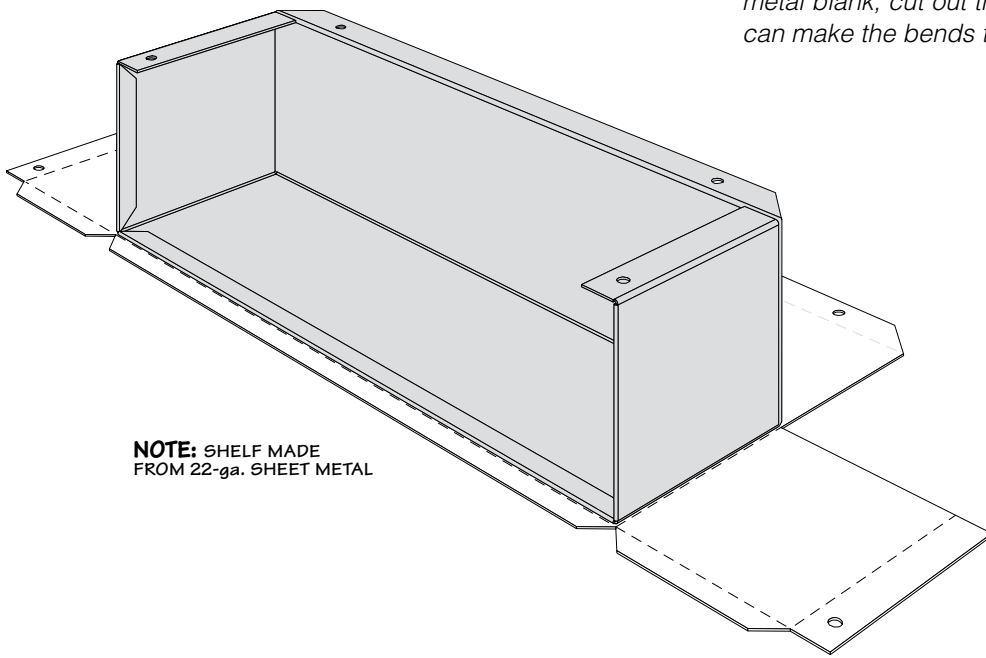

NOTE: SHELF MADE FROM 22-ga. SHEET METAL

END VIEW

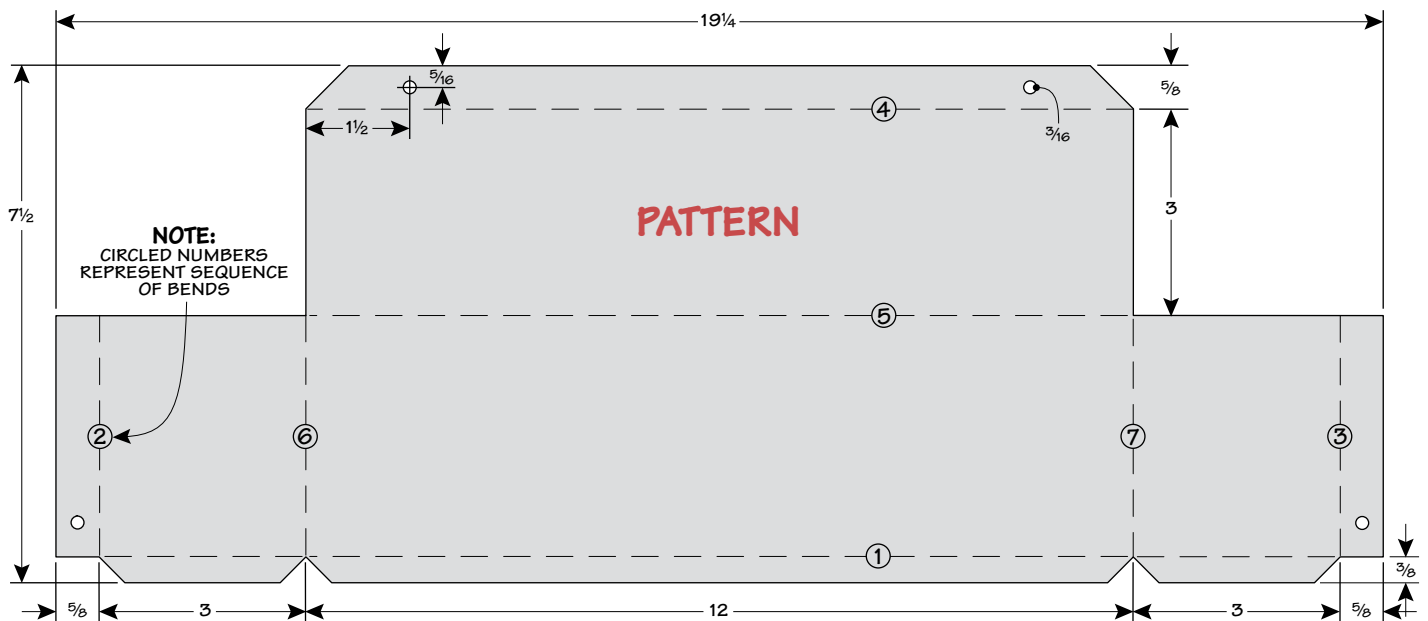
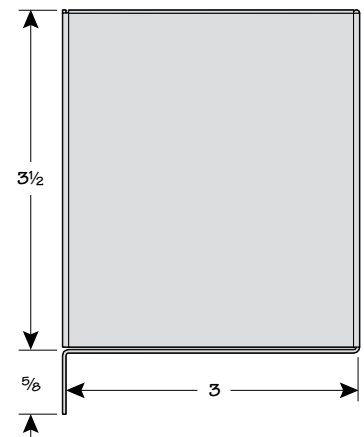

wall-mounted Tool Rack



▲ **Drill & Bend.** To create this wall-mounted tool rack, you start by drilling the holes. To complete it, you then make the four bends, as shown in the drawings and pattern below.

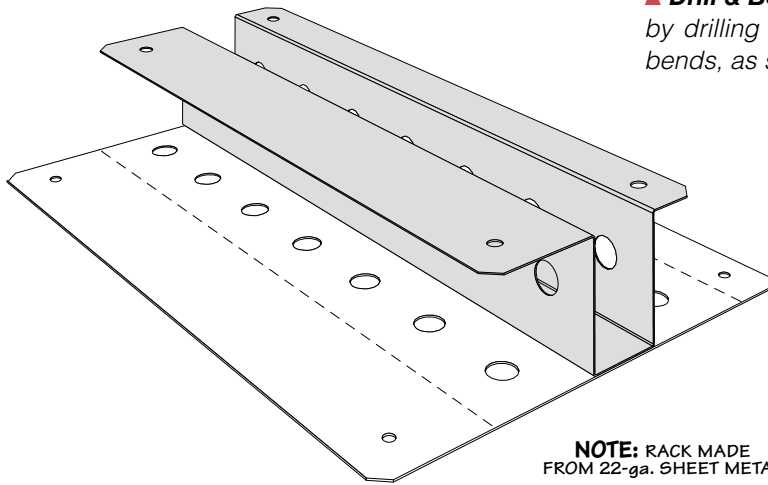

NOTE: RACK MADE FROM 22-ga. SHEET METAL

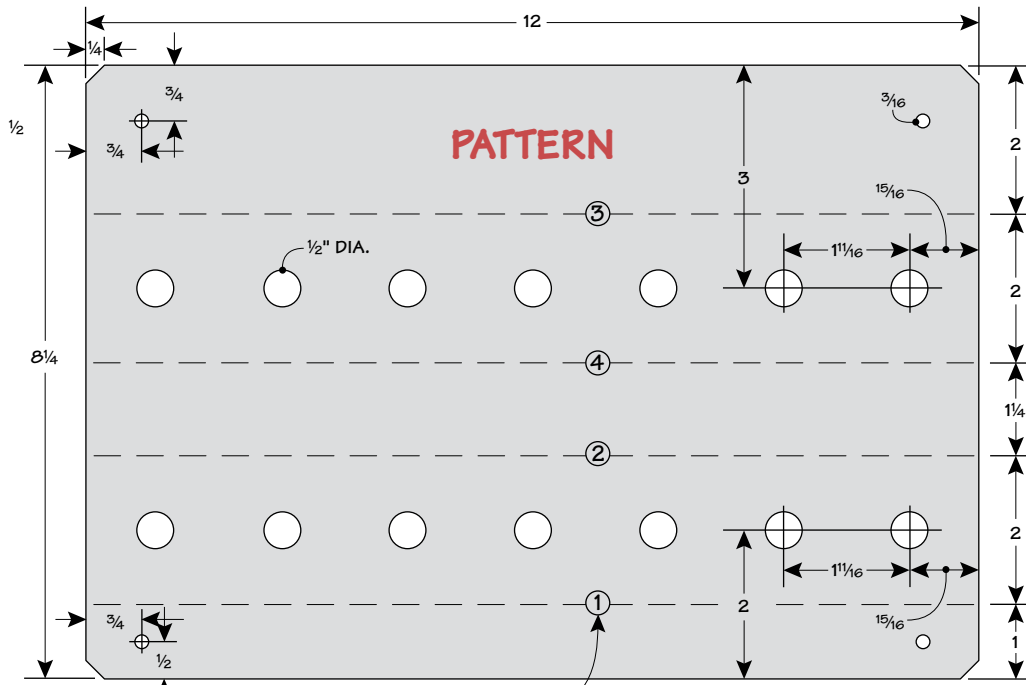
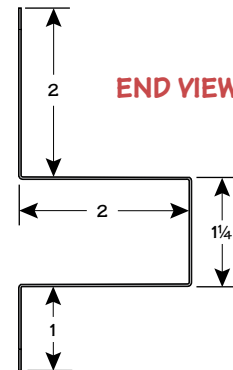

NOTE: CIRCLED NUMBERS REPRESENT SEQUENCE OF BENDS

easy access Bit Rack



▲ **Safe Router Bit Storage.** Rubber grommets help protect the delicate cutting edges and shafts of your router bits. The drawings below show how the rack is made.

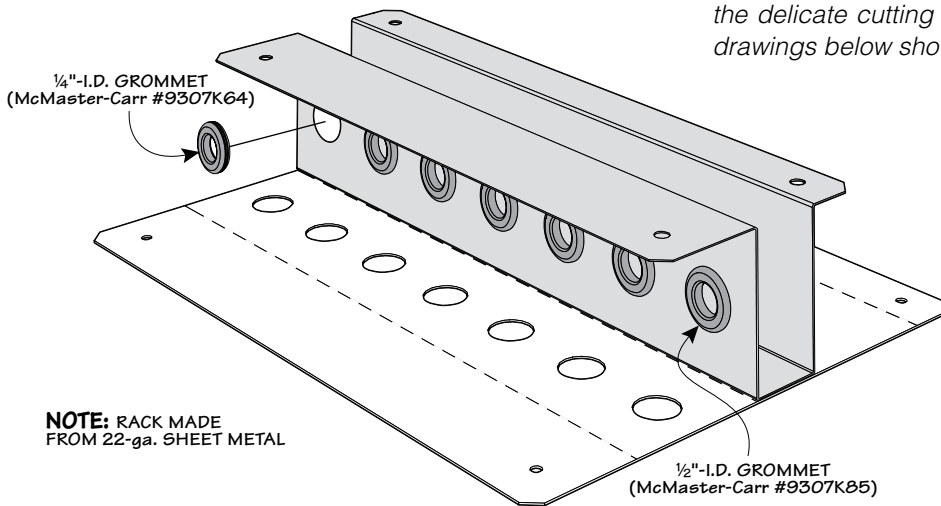

NOTE: RACK MADE FROM 22-ga. SHEET METAL

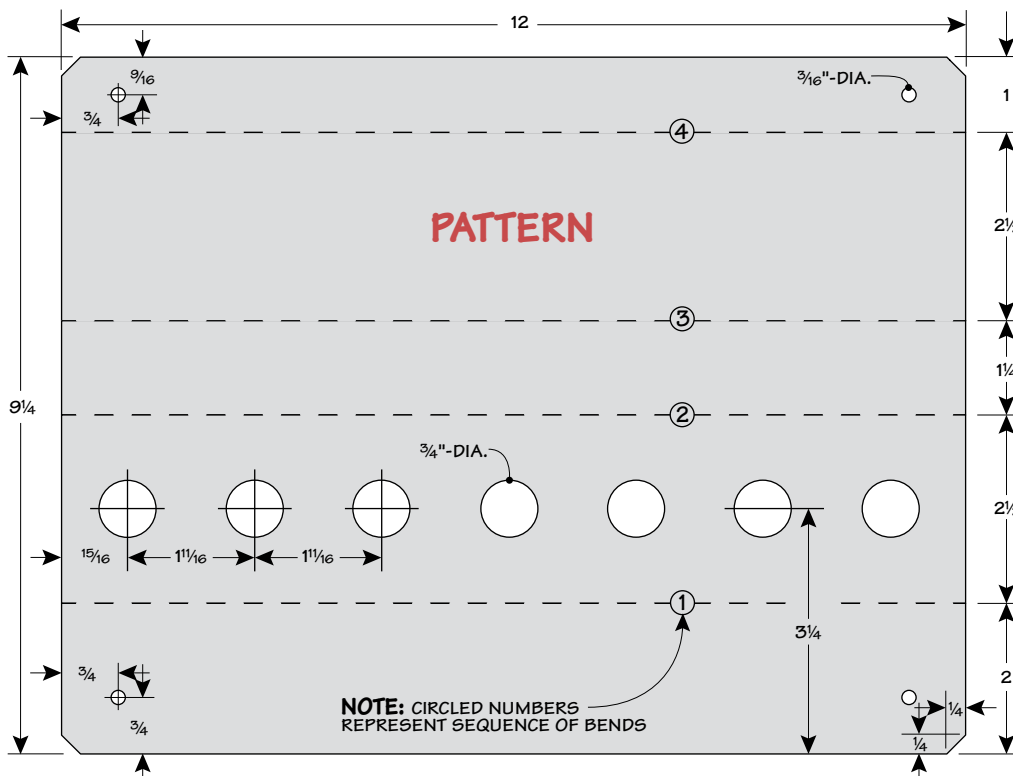
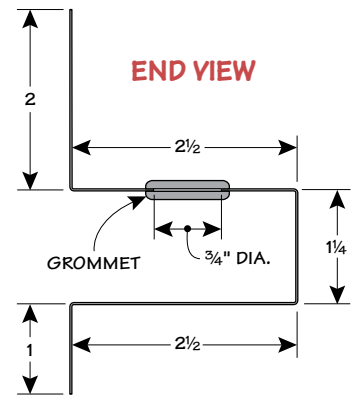

Stacked drawer Case

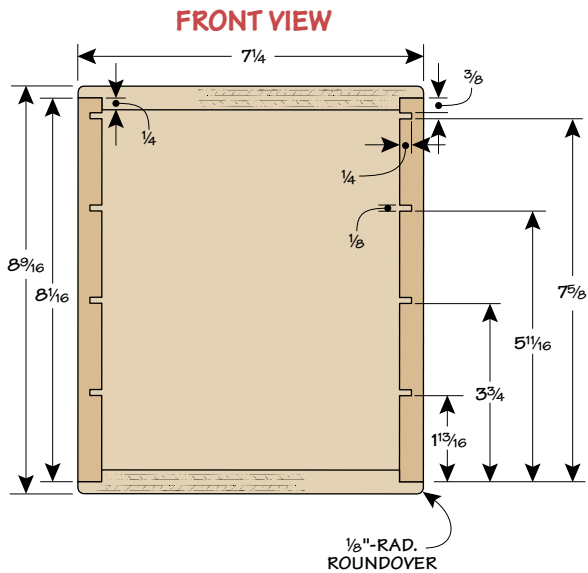

NOTE: ALL PARTS
MADE FROM 1/2" PLYWOOD

▲ **Simple Plywood Case.** This easy-to-build case holds the four drawers shown on the next page. Simple saw kerfs serve as the drawer slides.

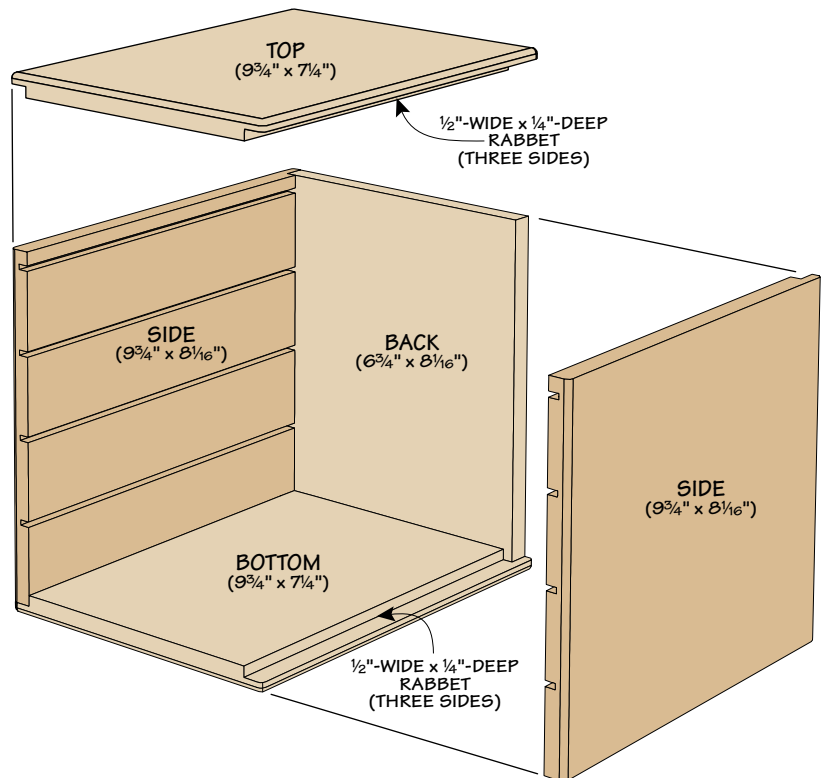

sheet metal Drawer



▲ **Fast & Easy Storage.** With four of these drawers and the case shown on the previous page, you can create handy storage for small items. And it doesn't take up much space on a shelf.

